

MAKE IT HAPPEN

FECON®



STUMPEX®

fecon.com
800 528 3113

sales@fecon.com
+1 513 696 4430

Whether you are buying, renting, or servicing your mulching equipment, FECON has solutions that focus on your success. Operator driven design with a global network that is woven into every product.



- Operators cab must be protected with both properly maintained 1/2" Polycarbonate Glass (or equal) and Falling Object Protection.
- Certain guarding and features may have been removed for illustrative purposes, always run with proper guarding.
- Weights may vary based on options.
- Specifications subject to change without notice.
- Photographs may have been altered for marketing purposes.
- Always insure that your carrier manufacturers safety features (including Falling Object Protection, and Roll-Over Protection) meet your job safety requirements.
- Safety Is The Responsibility Of The Operator.
- Pictures may contain optional accessories

STUMPEX®

FECON®



STUMP GRINDER

FECON.COM

800 528 3113

FECON® STUMP GRINDER SPECIFICATIONS

FECON 2-SPEED STUMPEX®	
	SHX33SVM
Mount	SS/CTL QA
Bit diameter	32"
Weight	1,368 lbs
Flow Range	20-42 gpm
Class	SSL / CTL / BHL / EXC (8-12 ton)
Pressure Range	2500-4000 psi

FASTER THAN TRADITIONAL STUMP GRINDERS				
	Stump Depth			
	8-14 in	15-21 in	22-28 in	
20 GPM	39-104 sec	115-180 sec	191-257 sec	
25 GPM	31-84 sec	93-146 sec	155-208 sec	
30 GPM	26-70 sec	77-121 sec	128-172 sec	
35 GPM	22-60 sec	66-104 sec	110-147 sec	
40 GPM	20-53 sec	58-91 sec	97-130 sec	
42 GPM	19-50 sec	55-87 sec	92-123 sec	

STANDARD CONFIGURATION
High torque, low RPM stump grinding bit
Two-speed hydraulic motor
Durable 3/4" AR500 steel cutting blades
Bore 28" stumps in single pass
Replaceable hardened steel cone
Safer work zone due to no flying debris
Universal SSL/CTL quick built into body (SHX33 only)
Carrier specific hydraulic hoses and couplers (SHX33SX only)
Fecon Standard Warranty - 6 months / 500 hours

LESS IS MORE

- ❖ No carbide tools to replace
- ❖ Low maintenance (grease & sharpen every 1,000 stumps)
- ❖ Low RPM auger bit (7-16 rpm) leads to easy clean-up and has no high speed flying debris for a safer work zone
- ❖ Fraction of work time compared to conventional stumpers
Replaceable Hardened Steel Cone

HOW IT WORKS

- ❖ Align Stumpex® vertically over the center of a stump
- ❖ Engage hydraulics and follow Stumpex without pushing or pulling - float function may be used
- ❖ Two-Speed motor will quickly thread cone into stump and then shift automatically into high torque
- ❖ Follow Stumpex® down, ensuring not to push or pull
- ❖ Two-Speed motor will shift back to high speed once through the bottom of the stump
- ❖ Lift Stumpex® vertically from hole and repeat process for stumps larger than 28"

SHX33SVM SKID STEER STUMPEX®

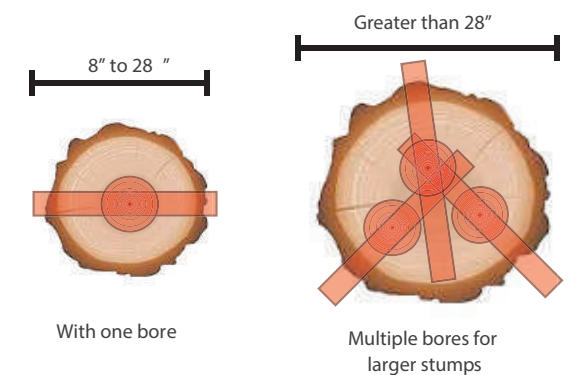
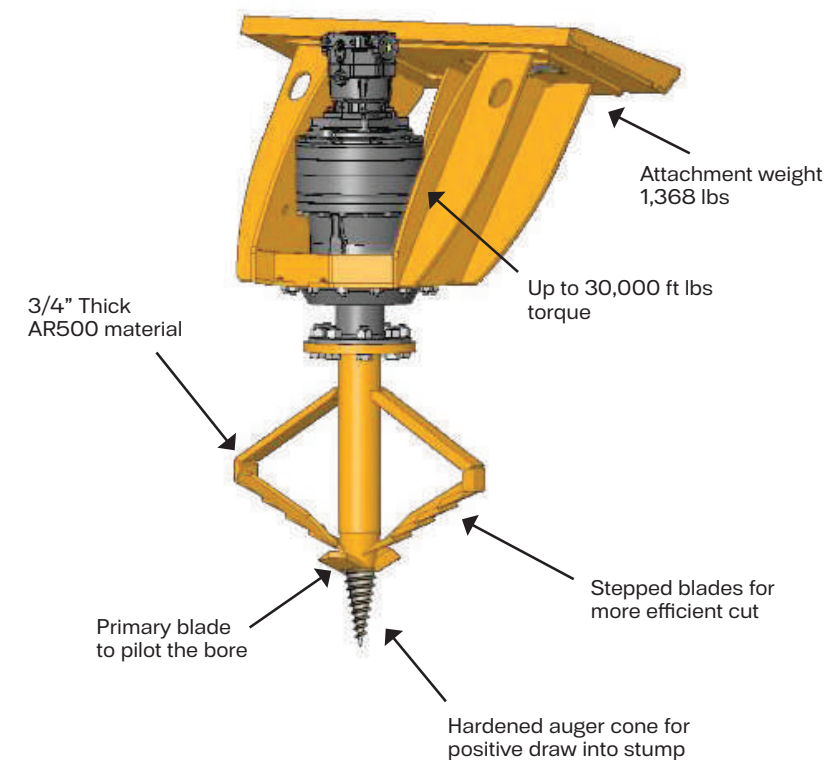

With one bore

Greater than 28"

Multiple bores for larger stumps